

# DC Input Modules

D2-32ND3 DC Input \$128.00	
<b>Inputs per Module</b>	32 (sink/source)
<b>Commons per Module</b>	4 isolated (8 I/O terminal points / com)
<b>Input Voltage Range</b>	20-28 VDC
<b>Peak Voltage</b>	30VDC
<b>ON Voltage Level</b>	19VDC minimum
<b>OFF Voltage Level</b>	7VDC maximum
<b>AC Frequency</b>	N/A
<b>Input Impedance</b>	4.8 kΩ
<b>Input Current</b>	8.0 mA @ 24VDC
<b>Minimum ON Current</b>	3.5 mA
<b>Maximum OFF Current</b>	1.5 mA
<b>Base Power Required 5VDC</b>	25mA
<b>OFF to ON Response</b>	3 to 9 ms
<b>ON to OFF Response</b>	3 to 9 ms
<b>Terminal Type (not included)</b>	40-pin Connector <sup>1</sup>
<b>Status Indicator</b>	Module Activity LED
<b>Weight</b>	2.1 oz. (60g)

<sup>1</sup> Connector sold separately.  
See Terminal Blocks and Wiring for wiring options.

D2-32ND3-2 DC Input \$128.00	
<b>Inputs per Module</b>	32 (Sink/Source)
<b>Commons per Module</b>	4 isolated (8 I/O terminal points / com)
<b>Input Voltage Range</b>	4.50 to 15.6 VDC min. to max.
<b>Peak Voltage</b>	16VDC
<b>ON Voltage Level</b>	4VDC minimum
<b>OFF Voltage Level</b>	2VDC maximum
<b>AC Frequency</b>	N/A
<b>Input Impedance</b>	1.0 kΩ @ 5-15 VDC
<b>Input Current</b>	4mA @ 5VDC 11mA @ 12VDC 14mA @ 15VDC
<b>Maximum Input Current</b>	16mA @ 15.6 VDC
<b>Minimum ON Current</b>	3mA
<b>Maximum OFF Current</b>	0.5 mA
<b>Base Power Required 5VDC</b>	25mA
<b>OFF to ON Response</b>	3 to 9 ms
<b>ON to OFF Response</b>	3 to 9 ms
<b>Terminal Type (not included)</b>	40-pin connector <sup>1</sup>
<b>Status Indicator</b>	Module activity LED
<b>Weight</b>	2.1 oz (60g)

<sup>1</sup> Connector sold separately.  
See Terminal Blocks and Wiring for wiring options.

See Wiring Solutions for part numbers of ZIPLink cables and connection modules compatible with this I/O module.

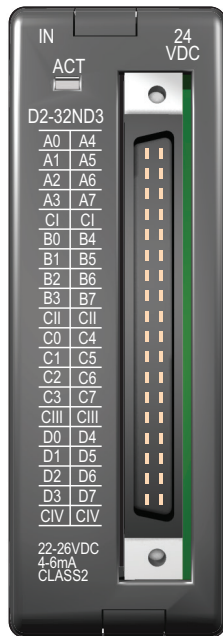
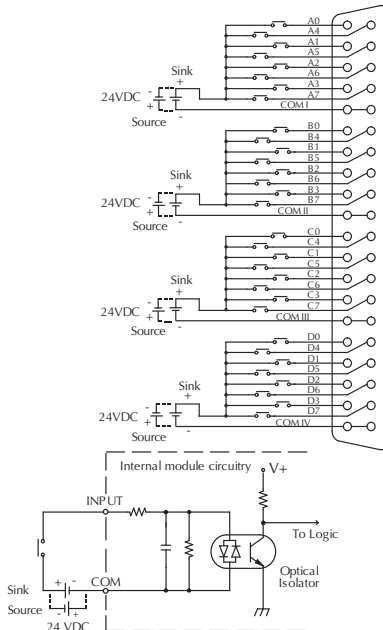
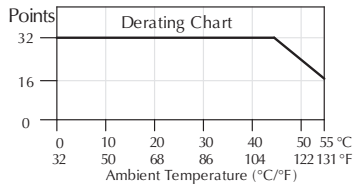

For "Sinking and Sourcing Concepts", see the Appendix section.

See Wiring Solutions for part numbers of ZIPLink cables and connection modules compatible with this I/O module.

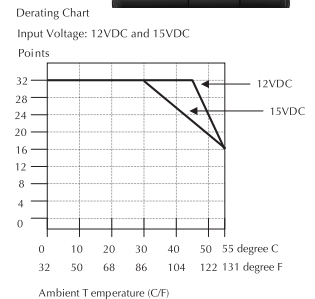
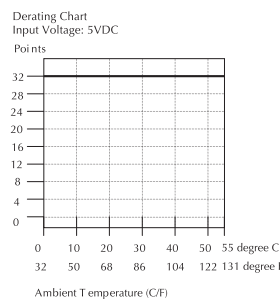
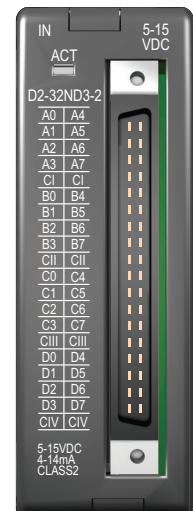
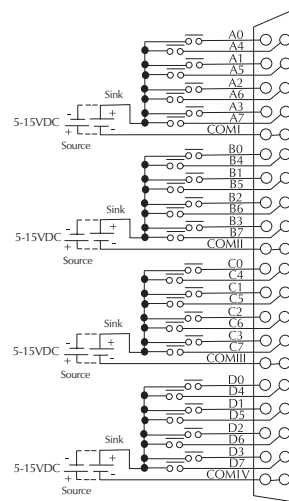

For "Sinking and Sourcing Concepts" see the Appendix section.

# AC Input Modules

D2-08NA-2 AC Input \$100.00	
<b>Inputs per Module</b>	8
<b>Commons per Module</b>	1 (2 I/O terminal points)
<b>Input Voltage Range</b>	170-265 VAC
<b>Peak Voltage</b>	265VAC
<b>ON Voltage Level</b>	150VAC minimum
<b>OFF Voltage Level</b>	40VAC maximum
<b>AC Frequency</b>	47-63 Hz
<b>Input Impedance</b>	18kΩ @ 60Hz
<b>Input Current</b>	9mA @ 220VAC, 50Hz 11mA @ 265VAC, 50Hz 10mA @ 220VAC, 60Hz 12mA @ 265VAC, 60Hz
<b>Minimum ON Current</b>	10mA
<b>Maximum OFF Current</b>	2mA
<b>Base Power Required 5VDC</b>	100mA
<b>OFF to ON Response</b>	5 to 30 ms
<b>ON to OFF Response</b>	10 to 50 ms
<b>Terminal Type (included)</b>	Removable; D2-8IOCON
<b>Status Indicator</b>	Logic side
<b>Weight</b>	2.5 oz. (70g)

<b>Operating Temperature</b>	32°F to 131°F (0° to 55°C)
<b>Storage Temperature</b>	-4°F to 158°F (-20°C to 70°C)
<b>Humidity</b>	35% to 95% (non-condensing)
<b>Atmosphere</b>	No corrosive gases permitted
<b>Vibration</b>	MIL STD 810C 514.2
<b>Shock</b>	MIL STD 810C 516.2
<b>Insulation Withstand Voltage</b>	1,500VAC 1 minute (COM-GND)
<b>Insulation Resistance</b>	10M Ω @ 500VDC
<b>Noise Immunity</b>	NEMA 1,500V 1 minute SANKI 1,000V 1 minute
<b>RFI</b>	150MHz, 430MHz



See Wiring Solutions for part numbers of ZIPLink cables and connection modules compatible with this I/O module.

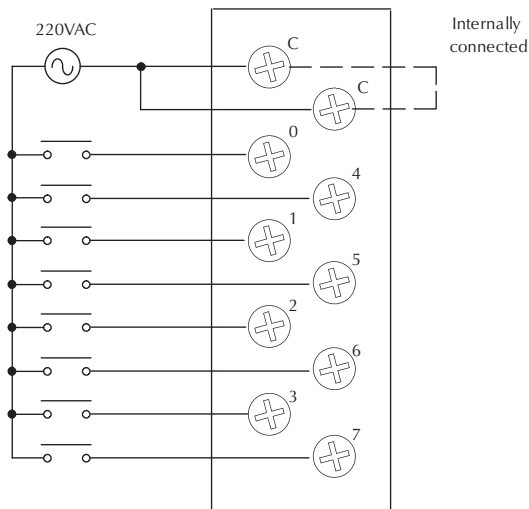
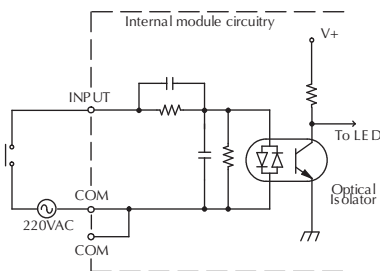
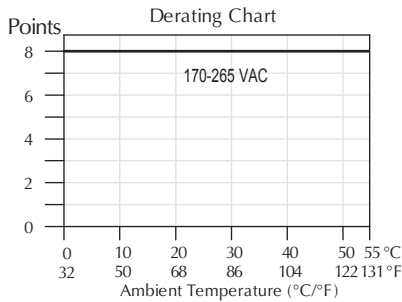

# AC Input Modules

D2-16NA AC Input \$138.00	
<b>Inputs per Module</b>	16
<b>Commons per Module</b>	2 (isolated)
<b>Input Voltage Range</b>	80-132 VAC
<b>Peak Voltage</b>	132VAC
<b>ON Voltage Level</b>	70VAC minimum
<b>OFF Voltage Level</b>	20VAC maximum
<b>AC Frequency</b>	47-63 Hz
<b>Input Impedance</b>	12 kΩ @ 60 Hz
<b>Input Current</b>	11mA @ 100VAC, 50Hz 13mA @ 100VAC, 60Hz 15mA @ 132VAC, 60Hz
<b>Minimum ON Current</b>	5mA
<b>Maximum OFF Current</b>	2mA
<b>Base Power Required 5VDC</b>	100mA
<b>OFF to ON Response</b>	5 to 30 ms
<b>ON to OFF Response</b>	10 to 50 ms
<b>Terminal Type (included)</b>	Removable; D2-16IOCON
<b>Status Indicator</b>	Logic side
<b>Weight</b>	2.4 oz. (68g)

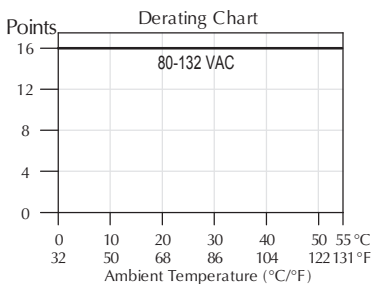

See Wiring Solutions for part numbers of ZIPLink cables and connection modules compatible with this I/O module.

**Note:** When used with the ZIPLink wiring system, relay outputs are derated not to exceed 2 Amps per point max.

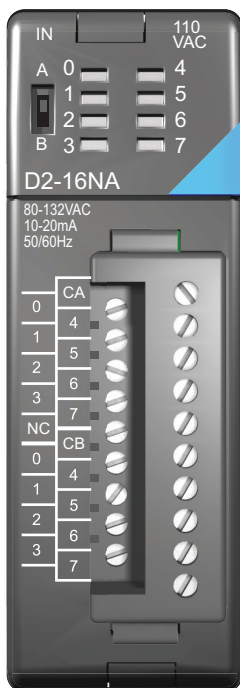
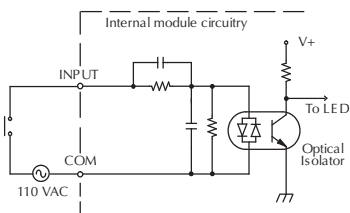
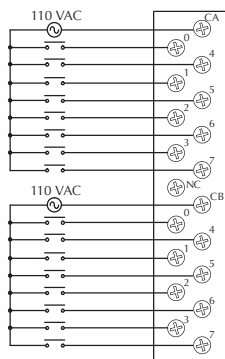

# DC Output Modules

D2-04TD1 DC Output \$69.00	
<b>Outputs per Module</b>	4 (current sinking)
<b>Output Points Consumed</b>	8 points (only first 4 pts. used)
<b>Commons per Module</b>	1 (4 I/O terminal points)
<b>Output Type</b>	NMOS FET (open drain)
<b>Operating Voltage</b>	10.2-26.4 VDC
<b>Peak Voltage</b>	40VDC
<b>ON Voltage Drop</b>	0.72 VDC maximum
<b>AC Frequency</b>	N/A
<b>Max Load Current (resistive)</b>	4A/point 8A/common
<b>Max Leakage Current</b>	0.1 mA @ 40VDC
<b>Max Inrush Current</b>	6A for 100ms, 15A for 10ms
<b>Minimum Load Current</b>	50mA

<b>External DC Required</b>	24VDC @ 20mA max.
<b>Base Power Required 5VDC</b>	60mA
<b>OFF to ON Response</b>	1ms
<b>ON to OFF Response</b>	1ms
<b>Terminal Type (included)</b>	Removable; D2-8IOCON
<b>Status Indicator</b>	Logic side
<b>Weight</b>	2.8 oz. (80g)
<b>Fuses</b>	4 (1 per point) (6.3 A slow blow, non-replaceable)



See Wiring Solutions for part numbers of ZIPLink cables and connection modules compatible with this I/O module.

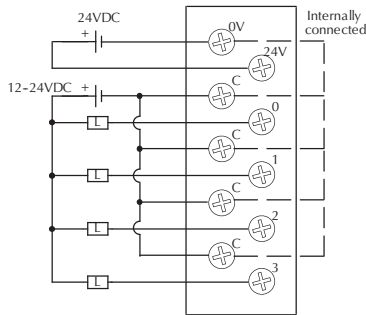
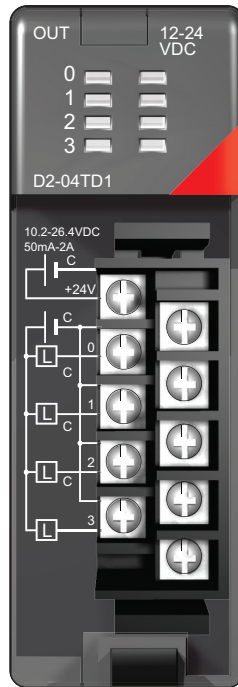
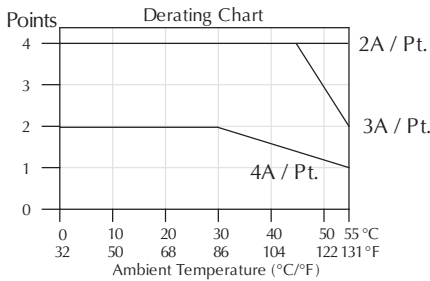

Inductive Load  
Maximum Number of Switching Cycles per Minute

Load Current	Duration of output in ON state		
	7ms	40ms	100ms
0.1A	8000	1400	600
0.5A	1600	300	120
1.0A	800	140	60
1.5A	540	90	35
2.0A	400	70	-
3.0A	270	-	-
4.0A	200	-	-

**At 40ms duration, loads of 3.0 A or greater cannot be used.**

**At 100ms duration, loads of 2.0 A or greater cannot be used.**

Find the load current you expect to use and the duration that the output is ON. The number at the intersection of the row and column represents the switching cycles per minute. For example, a 1A inductive load that is on for 100ms can be switched on and off a maximum of 60 times per minute. To convert this to duty cycle percentage use:  $(\text{duration} \times \text{cycles}) / 60$ . In this example,  $(60 \times .1) / 60 = .1$ , or 10% duty cycle.

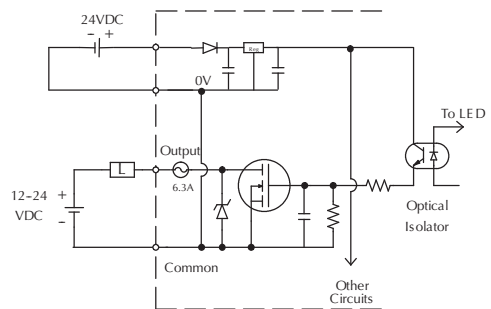



# Power Requirements

## These charts help determine your power requirements

This section shows the amount of power supplied by each of the base power supplies and the amount of power consumed by each DL205 device. The Power Consumed charts list how much INTERNAL power from each power source is required for the DL205 devices. Use this information when calculating the power budget for your system.

In addition to the internal power sources, the DL205 bases offer a 24 VDC auxiliary power supply with external power connections. This auxiliary power supply can power external devices.

## Use ZIPLinks to reduce power requirements

If your application requires a lot of relay outputs, consider using the ZIPLink AC or DC relay output modules. These modules can switch high current (10A) loads without putting a load on your base power budget. Refer to the Terminal Blocks and Wiring Solutions section in this catalog for more information.

This logo is placed next to the I/O modules that are supported by the ZIPLink connection systems. See the I/O module specifications at the end of this section.



Power Consumed		
Device	5V(mA)	24V Auxiliary
<b>Operator Interface</b>		
DV-1000	150	0
C-more Micro-Graphic	210	0

Power Supplied			
Device	Price	5V(mA)	24V Auxiliary
<b>Bases</b>			
D2-03B-1	\$134.00	2600	300
D2-03BDC1-1	\$152.00	2600	None
D2-04B-1	\$146.00	2600	300
D2-04BDC1-1	\$173.00	2600	None
D2-06B-1	\$179.00	2600	300

Power Consumed		
Device	5V(mA)	24V Auxiliary
<b>CPUs</b>		
D2-250-1	330	0
D2-260	330	0
D2-262	336	0
<b>DC Input Modules</b>		
D2-08ND3	50	0
D2-16ND3-2	100	0
D2-32ND3	25	0
D2-32ND3-2	25	0
<b>AC Input Modules</b>		
D2-08NA-1	50	0
D2-08NA-2	100	0
D2-16NA	100	0
<b>Input Simulator Module</b>		
F2-08SIM	50	0
<b>DC Output Modules</b>		
D2-04TD1	60	20
D2-08TD1	100	0
D2-08TD2	100	0
D2-16TD1-2	200	80
D2-16TD2-2	200	0
F2-16TD1P	70	50
F2-16TD2P	70	50
D2-32TD1	350	0
D2-32TD2	350	0
<b>AC Output Modules</b>		
D2-08TA	250	0
F2-08TA	250	0
D2-12TA	350	0
<b>Relay Output Modules</b>		
D2-04TRS	250	0
D2-08TR	250	0
F2-08TR(S)	670	0
D2-12TR	450	0
<b>Combination In/Out Module</b>		
D2-08CDR	200	0

Power Supplied			
Device	Price	5V(mA)	24V Auxiliary
<b>Bases</b>			
D2-06BDC1-1	\$197.00	2600	None
D2-06BDC2-1	\$187.00	2600	300
D2-09B-1	\$223.00	2600	300
D2-09BDC1-1	\$243.00	2600	None
D2-09BDC2-1	\$243.00	2600	300

Power Consumed		
Device	5V(mA)	24V Auxiliary
<b>Analog Modules</b>		
F2-04AD-1	100	5
F2-04AD-2	110	5
F2-08AD-1	100	5
F2-08AD-2	100	5
F2-02DA-1	40	60 (note 1)
F2-02DA-1L	40	70 @ 12V (note 1)
F2-02DA-2	40	60
F2-02DA-2L	40	70 @ 12V
F2-02DAS-1	100	50 / channel
F2-02DAS-2	100	60 / channel
F2-08DA-1	30	50 (note 1)
F2-08DA-2	60	140
F2-4AD2DA	60	80 (note 1)
F2-8AD4DA-1	35	100 (note 1)
F2-8AD4DA-2	35	80 (note 1)
F2-04RTD	90	0
F2-04THM	110	60
<b>Specialty Modules</b>		
D2-CTRINT	50*	0
D2-CM / D2-EM	100/130	0
H2-CTRIO2	275	0
D2-DCM	300	0
H2-EBC100	300	0
H2-EBC-F	640	0
H2-ECOM100	300	0
H2-ECOM-F	640	0
F2-CP128	235	0
<b>Remote I/O</b>		
H2-ERM100, (-F)	300, (-F: 450)	0
<b>Programming Devices</b>		
D2-HPP	200	0

\*requires external 5VDC for outputs  
Note 1: Add an additional 20 mA per output loop.